

# 75x24 mm (3x0.98 in)

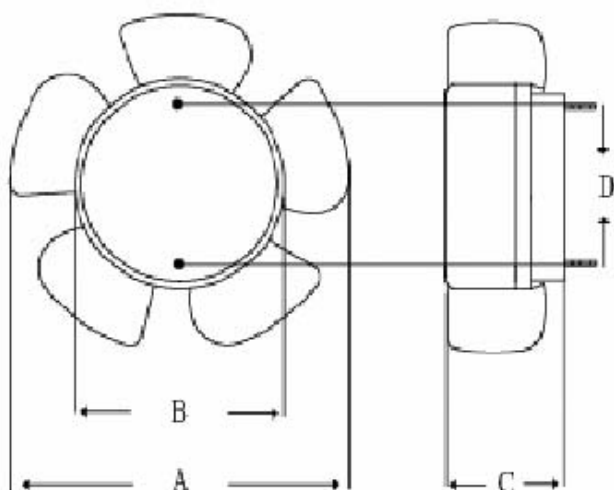

**Impeller:** Thermoplastic PBT  
**Ambient Temperature Range:** -20°C ~ +70°C  
**Operating Voltage Range:** Rated Voltage  $\pm 10\%$   
**Bearing:** Ball  
**Motor Structure:** shaded-pole motor  
**Motor protection:** Impedance Protected  
**Termination:** Lead wire  
**CFM:** 25~13  
**Weight:** 220a / PC.

**Dimensions:** AxBxCxD: Dia.75x24mm/3inch, Plastic



Mounting Screw x2  
M3.5 x 0.6P  
L: 11.5 +- 1mm

\*Screw Length can be changed  
to meet customer requirement.

AC Axial Fan

## SPECIFICATION

1. Voltages: 100, 115, 200, 230, 240.
2. Frequency: 50/60 Hz.
3. Dual voltage types & special voltage: 12, 24, 28, 42, 48, 380, 440, 480 are available on request.
4. We reserve the right to change data without notice.



風速達科技有限公司

電話：07-3634386

電郵：sales@fanmotor.com.tw

傳真：07-3631283

網址：www.fanmotor.com.tw

行動：0929-045065

地址：(81147)高雄市楠梓區盛昌街23巷18號